

Device Driver Architecture

Brian Chang, 22 July 2002

Brian_c@castlenet.com.tw

2002 Linux kernel trace seminar



A split view of the kernel

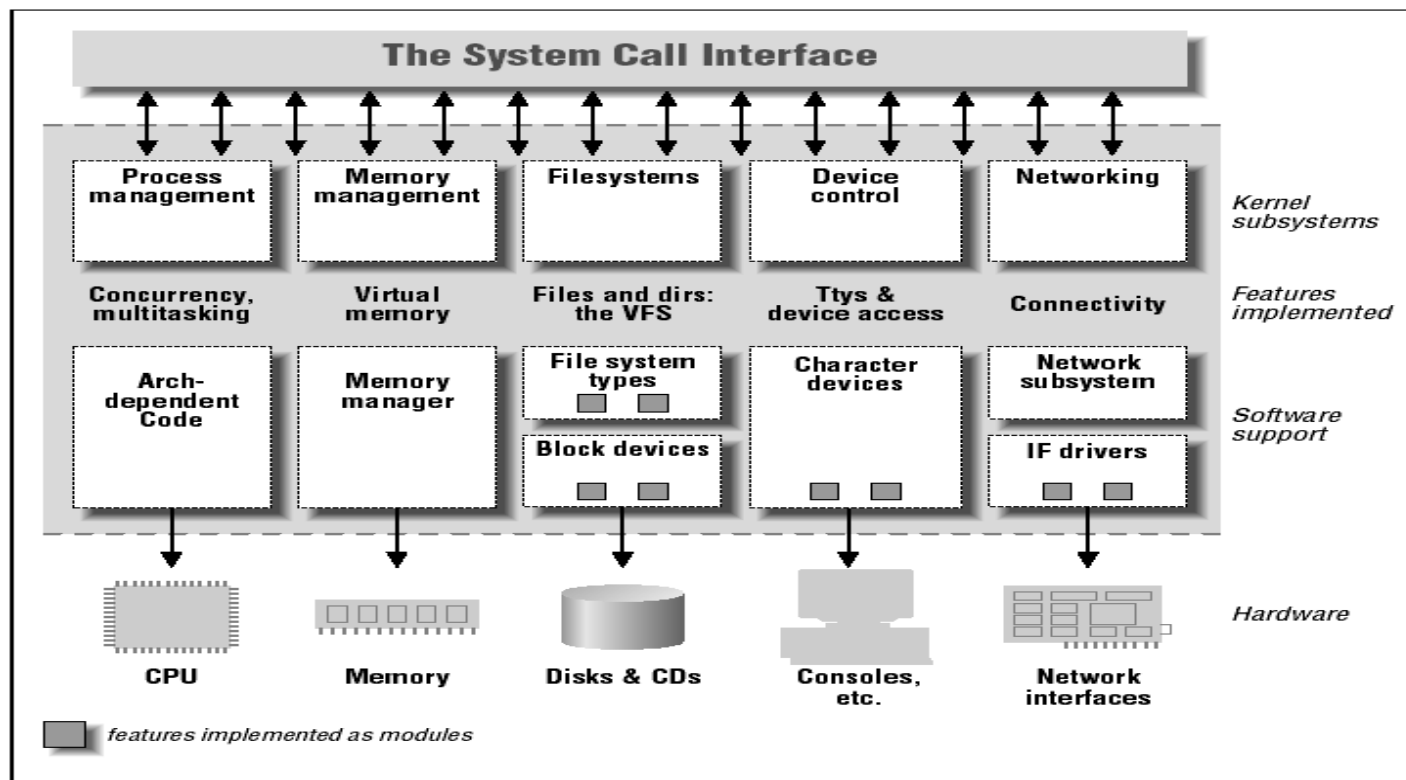

PC's I/O Device Architecture

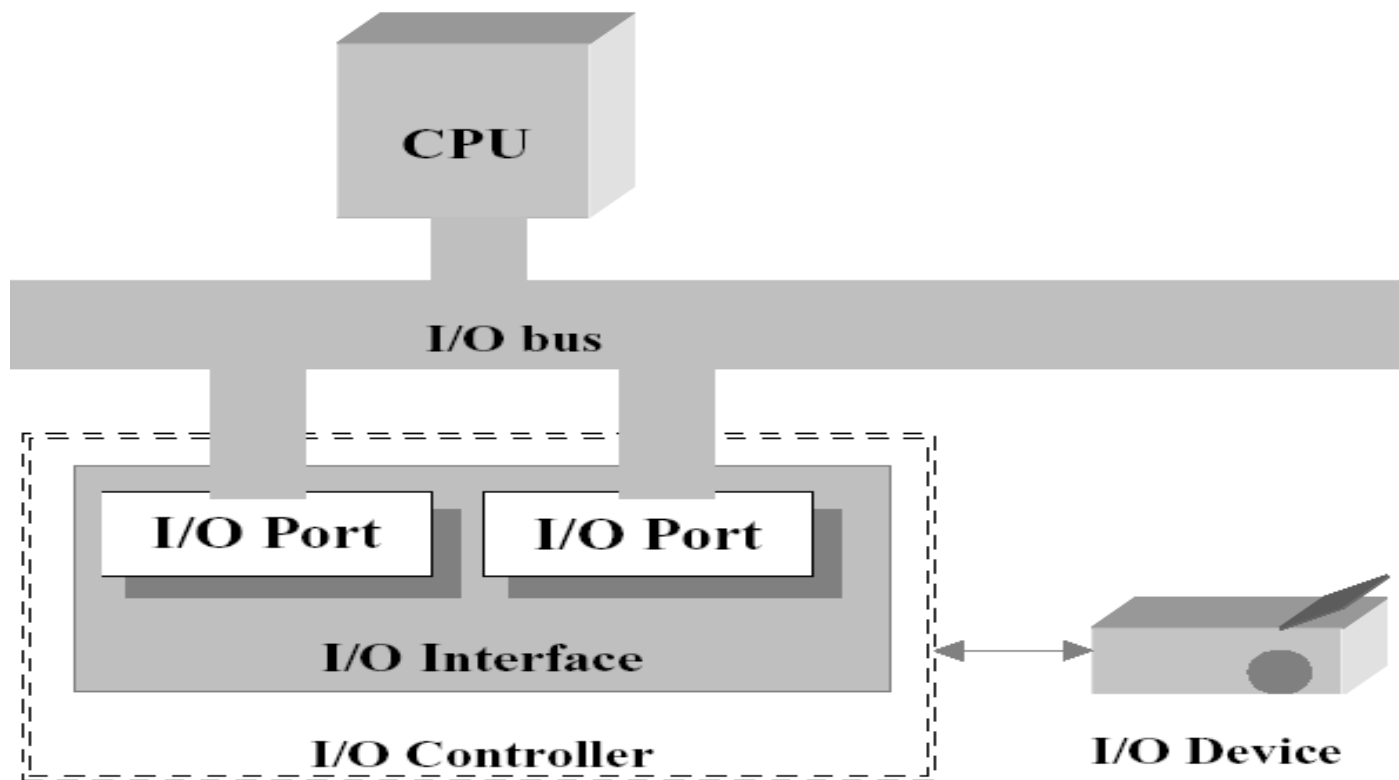

Device Files

Each device file has three attributes

- | Type – either block or character
- | Major number – from 1 to 255
- | Minor number – from 0 to 255

ex.:

- | | | | | |
|---------------------|-------|---|---|-----------------|
| dev/had | block | 3 | 0 | first IDE disk |
| dev/tty0
console | char | 4 | 0 | current virtual |

Reference: Documentation/devices.txt (Major number)

Device Driver Load

- I **Statically** : the corresponding device file class is registered during system initialization
- I **Dynamically** : the corresponding file class is registered/unregistered when a module is loaded/unloaded

Device file descriptors (1)

- | **chrdevs table:** all `device_struct` descriptors for character device files are included in the `chrdevs` table
- | **blkdevs table:** all `device_struct` descriptors for block device files are included in the `blkdevs` table

Device file descriptors (2)

/fs/devices.c

```
struct device_struct {
    const char * name;
    struct file_operations * fops;
};
static struct device_struct chrdevs[MAX_CHRDEV];
```

/fs/block_dev.c

```
static struct {
    const char *name;
    struct block_device_operations *bdops;
} blkdevs[MAX_BLKDEV];
```

```
/include/linux/major.h
#define MAX_CHRDEV 255
#define MAX_BLKDEV 255
```

Character device file operations

/include/linux/fs.h

```
struct file_operations {
    struct module *owner;
    loff_t (*llseek) (struct file *, loff_t, int);
    ssize_t (*read) (struct file *, char *, size_t, loff_t *);
    ssize_t (*write) (struct file *, const char *, size_t, loff_t *);
    int (*readdir) (struct file *, void *, filldir_t);
    unsigned int (*poll) (struct file *, struct poll_table_struct *);
    int (*ioctl) (struct inode *, struct file *, unsigned int, unsigned long);
    int (*mmap) (struct file *, struct vm_area_struct *);
    int (*open) (struct inode *, struct file *);
    . . . . .
```

Character device file operations

/include/linux/fs.h

```
struct file_operations {  
    . . . . .  
    int (*flush) (struct file *);  
    int (*release) (struct inode *, struct file *);  
    int (*fsync) (struct file *, struct dentry *, int datasync);  
    int (*fasync) (int, struct file *, int);  
    int (*lock) (struct file *, int, struct file_lock *);  
    ssize_t (*readv) (struct file *, const struct iovec *, unsigned long, loff_t *);  
    ssize_t (*writev) (struct file *, const struct iovec *, unsigned long, loff_t *);  
    . . . . .  
};
```

Character device file operations

/include/linux/fs.h

```
struct file_operations {
```

```
    . . . . .
```

```
    ssize_t (*sendpage) (struct file *, struct page *, int, size_t, loff_t *, int);
```

```
    unsigned long (*get_unmapped_area)(struct file *, unsigned long, unsigned long,  
    unsigned long, unsigned long);
```

```
};
```

Block device file operations

/include/linux/fs.h

```
struct block_device_operations {
    int (*open) (struct inode *, struct file *);
    int (*release) (struct inode *, struct file *);
    int (*ioctl) (struct inode *, struct file *, unsigned, unsigned long);
    int (*check_media_change) (kdev_t);
    int (*revalidate) (kdev_t);
    struct module *owner;
};
```

The file structure (1)

/include/linux/fs.h

```
struct file {
    struct list_head    f_list;
    struct dentry       *f_dentry;
    struct vfsmount     *f_vfsmnt;
    struct file_operations *f_op;
    atomic_t           f_count;
    unsigned int        f_flags;
    mode_t              f_mode;
    loff_t              f_pos;
    unsigned long       f_reada, f_ramax, f_raend, f_ralen, f_rawin;
    struct fown_struct  f_owner;
    unsigned int        f_uid, f_gid;
    . . . . .
```

The file structure (2)

/include/linux/fs.h

```
struct file {  
    . . . . .  
    int                f_error;  
    unsigned long      f_version;  
  
    /* needed for tty driver, and maybe others */  
    void                *private_data;  
  
    /* preallocated helper kiobuf to speedup O_DIRECT */  
    struct kiobuf       *f_iobuf;  
    long                f_iobuf_lock;  
};
```

Device Register/Unregister (1)

I Register

init_module()

→ *devfs_register_chrdev()/ devfs_register_blkdev()*

→ *register_chrdev() / register_blkdev ()*

I Unregister

cleanup_module ()

→ *devfs_unregister_chrdev() / devfs_unregister_blkdev()*

→ *unregister_chrdev()/unregister_blkdev()*

Device Register/Unregister (2)

/fs/devices.c

```
int register_chrdev(unsigned int major, const char * name, struct  
    file_operations *fops)
```

```
int unregister_chrdev(unsigned int major, const char * name)
```

/fs/block_dev.c

```
int register_blkdev(unsigned int major, const char * name, struct  
    block_device_operations *bdops)
```

```
int unregister_blkdev(unsigned int major, const char * name)
```

Monitoring I/O Operations -- Polling Mode

I Polling mode

Ex. lp.c

```
static ssize_t lp_write( . . . ){  
    . . . . .  
    do{  
        . . . . .  
        if (copy_size > 0) {  
            . . . . .  
        } else if (current->need_resched)  
            schedule ();  
        . . . . .  
    } while (count > 0); . . . }
```

Monitoring I/O Operations -- Interrupt Mode (1)

I Interrupt Mode

Ex. serial.c

```
static int startup(struct async_struct * info)
{
    . . . . .
    retval = request_irq(state->irq, handler, SA_SHIRQ, "serial", &IRQ_ports[state->irq]);
    . . . . .
}
static int rs_ioctl(struct tty_struct *tty, struct file * file,
                   unsigned int cmd, unsigned long arg)
{
    . . . . .
    case TIOCMWAIT:
        . . . . .
        interruptible_sleep_on(&info->delta_msr_wait);
        . . . . .
}
```

Monitoring I/O Operations -- Interrupt Mode (2)

```
static void rs_interrupt(int irq, void *dev_id, struct pt_regs * regs)
{
    . . . . .
    check_modem_status(info);
    . . . . .
}
static _INLINE_ void check_modem_status(struct async_struct *info)
{
    . . . . .
    if (status & UART_MSR_ANY_DELTA) {
        . . . . .
        wake_up_interruptible(&info->delta_msr_wait); }
    . . . . .
}
```

Generic parallel printer driver (1)

/drivers/char/lp.c

If this driver is built into the kernel, you can configure it using the kernel command-line. For example:

lp=parport1,none,parport2 (bind lp0 to parport1, disable lp1 and
bind lp2 to parport2)

lp=auto (assign lp devices to all ports that
have printers attached, as determined
by the IEEE-1284 autoprobe)

lp=reset (reset the printer during
initialisation)

lp=off (disable the printer driver entirely)

Generic parallel printer driver (2)

/drivers/char/lp.c

If the driver is loaded as a module, similar functionality is available using module parameters. The equivalent of the above commands would be:

```
# insmod lp.o parport=1,none,2
```

```
# insmod lp.o parport=auto
```

```
# insmod lp.o reset=1
```

Generic parallel printer driver (3)

/drivers/char/lp.c

• • • • •

```
__setup("lp=", lp_setup);  
module_init(lp_init_module);  
module_exit(lp_cleanup_module);
```

Generic parallel printer driver (4)

/drivers/char/lp.c

```
static int __init lp_init_module (void)
{
    if (parport[0]) {
        if (!strncmp(parport[0], "auto", 4))
            parport_nr[0] = LP_PARPORT_AUTO;
        else {
            . . . . .
        }
    }
    return lp_init();
}
```

Generic parallel printer driver (5)

/drivers/char/lp.c

```
int __init lp_init (void)
{
    . . . . .
    if (devfs_register_chrdev (LP_MAJOR, "lp", &lp_fops)) {
        printk ("lp: unable to get major %d\n", LP_MAJOR);
        return -EIO;
    }
    devfs_handle = devfs_mk_dir (NULL, "printers", NULL);
    if (parport_register_driver (&lp_driver)) {
        printk ("lp: unable to register with parport\n");
        return -EIO;
    }
}
```

```
/include/asm-i386/errno.h
#define EIO 5 /* I/O error */
```

Generic parallel printer driver (5a)

/drivers/char/lp.c

```
static struct file_operations  
lp_fops = {
```

```
    owner:    THIS_MODULE,
```

```
    write:    lp_write,
```

```
    ioctl:    lp_ioctl,
```

```
    open:     lp_open,
```

```
    release:  lp_release,
```

```
#ifdef CONFIG_PARPORT_1284
```

```
    read:     lp_read,
```

```
#endif};
```

```
    R, "lp", &lp_fops)) {  
    %d\n", LP_MAJOR);
```

```
    "printers", NULL);
```

```
    er)) {
```

```
    printk ("lp: unable to register with parport\n");
```

```
    return -EIO;
```

```
}
```

Generic parallel printer driver (6)

/drivers/char/lp.c

```
int __init lp_init (void)
{
    . . . . .
    if (!lp_count) {
        printk (KERN_INFO "lp: driver loaded but no devices found\n");
#ifdef CONFIG_PARPORT_1284
        if (parport_nr[0] == LP_PARPORT_AUTO)
            printk (KERN_INFO "lp: (is IEEE 1284 support enabled?)\n");
#endif
    }

    return 0;
}
```

Generic parallel printer driver (7)

/fs/devfs/base.c

```
int devfs_register_chrdev (unsigned int major, const char *name,  
                           struct file_operations *fops)  
{  
    if (boot_options & OPTION_ONLY) return 0;  
    return register_chrdev (major, name, fops);  
} /* End Function devfs_register_chrdev */
```

Generic parallel printer driver (8)

/fs/devfs/devices.c

```
int register_chrdev(unsigned int major, const char * name, struct file_operations *fops)
{
    if (major == 0) {
        write_lock(&chrdevs_lock);
        for (major = MAX_CHRDEV-1; major > 0; major--) {
            if (chrdevs[major].fops == NULL) {
                chrdevs[major].name = name;
                chrdevs[major].fops = fops;
                write_unlock(&chrdevs_lock);
                return major;
            }
        }
        write_unlock(&chrdevs_lock);
        return -EBUSY;
    }
}
```

Generic parallel printer driver (9)

/fs/devfs/devices.c

```
int register_chrdev(unsigned int major, const char * name, struct file_operations *fops)
{
    . . . . .
    if (major >= MAX_CHRDEV)
        return -EINVAL;
    write_lock(&chrdevs_lock);
    if (chrdevs[major].fops && chrdevs[major].fops != fops) {
        write_unlock(&chrdevs_lock);
        return -EBUSY;
    }
    chrdevs[major].name = name;
    chrdevs[major].fops = fops;
    write_unlock(&chrdevs_lock);
    return 0;
}
```

/include/linux/major.h
#define MAX_CHRDEV 255

Generic parallel printer driver (10)

/drivers/char/lp.c

```
static void lp_cleanup_module (void)
{
    unsigned int offset;
    parport_unregister_driver (&lp_driver);
#ifdef CONFIG_LP_CONSOLE
    unregister_console (&lpcons);
#endif
    devfs_unregister (devfs_handle);
    devfs_unregister_chrdev(LP_MAJOR, "lp");
    for (offset = 0; offset < LP_NO; offset++) {
        if (lp_table[offset].dev == NULL)
            continue;
        parport_unregister_device(lp_table[offset].dev);
    }
}
```

Generic parallel printer driver (11)

/fs/devfs/base.c

```
int devfs_unregister_chrdev (unsigned int major, const char *name)
{
    if (boot_options & OPTION_ONLY) return 0;
    return unregister_chrdev (major, name);
} /* End Function devfs_unregister_chrdev */
```

Generic parallel printer driver (12)

/fs/devfs/devices.c

```
int unregister_chrdev(unsigned int major, const char * name)
{
    if (major >= MAX_CHRDEV)
        return -EINVAL;
    write_lock(&chrdevs_lock);
    if (!chrdevs[major].fops || strcmp(chrdevs[major].name, name)) {
        write_unlock(&chrdevs_lock);
        return -EINVAL;
    }
    chrdevs[major].name = NULL;
    chrdevs[major].fops = NULL;
    write_unlock(&chrdevs_lock);
    return 0;
}
```

Generic parallel printer driver (13)

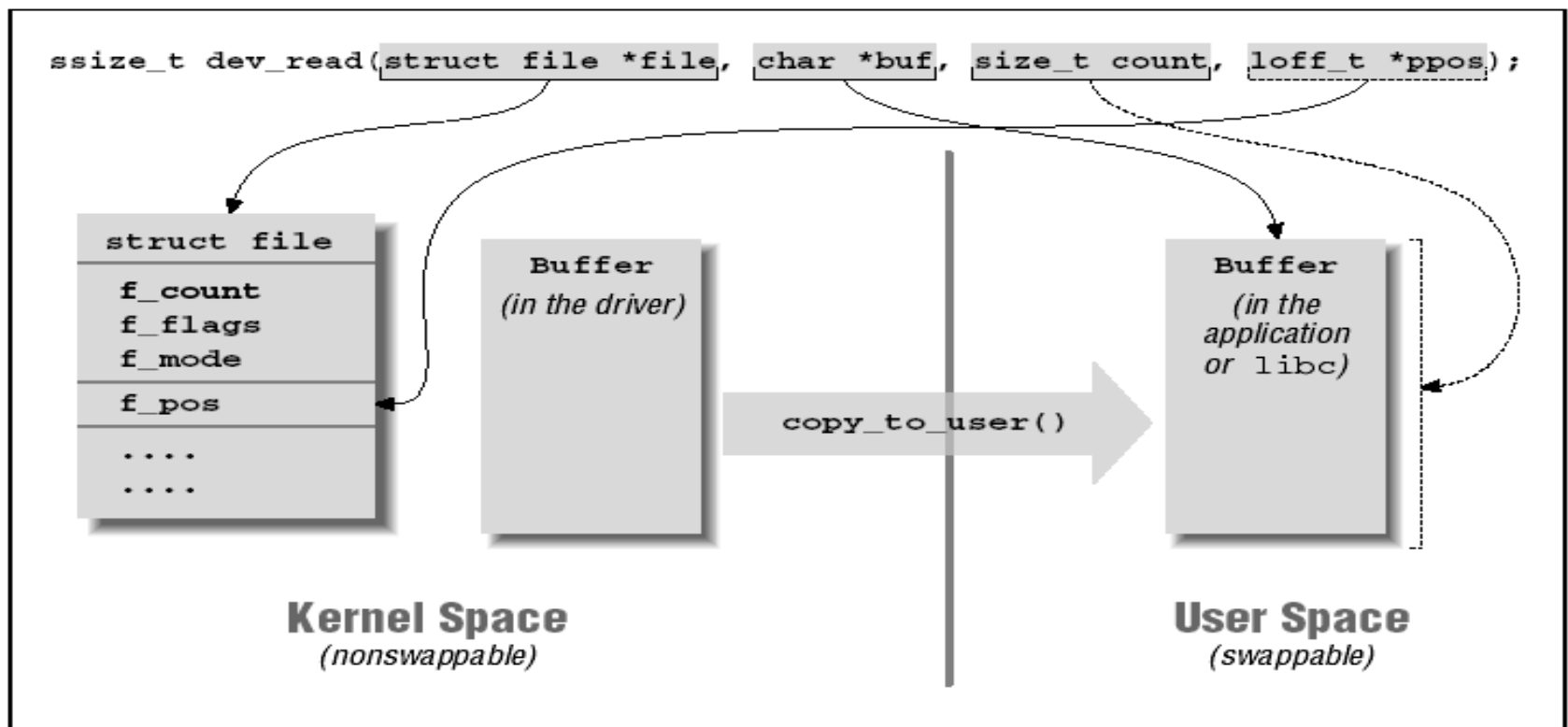

Generic parallel printer driver (14)

/drivers/char/lp.c

```
static ssize_t lp_read(struct file * file, char * buf, size_t count, loff_t *ppos) {  
    . . . . .  
    if (copy_from_user (kbuf, buf, copy_size))  
        return -EFAULT;  
    . . . . .  
}
```

/drivers/char/rocket.c

```
int copy_from_user(void *to, const void *from_user, unsigned long len) {  
    int error;  
    error = verify_area(VERIFY_READ, from_user, len);  
    if (error)  
        return len;  
    memcpy_fromfs(to, from_user, len);  
    return 0;  
}
```

Generic parallel printer driver (15)

/drivers/char/lp.c

```
static ssize_t lp_write(struct file * file, const char * buf, size_t count, loff_t *ppos){
    . . . . .
    if (copy_from_user (kbuf, buf, copy_size))
        return -EFAULT;
    . . . . .
}
```

/drivers/char/rocket.c

```
int copy_from_user(void *to, const void *from_user, unsigned long len){
    int error;
    error = verify_area(VERIFY_READ, from_user, len);
    if (error)
        return len;
    memcpy_fromfs(to, from_user, len);
    return 0;
}
```

Registering a Block Device Driver(1)

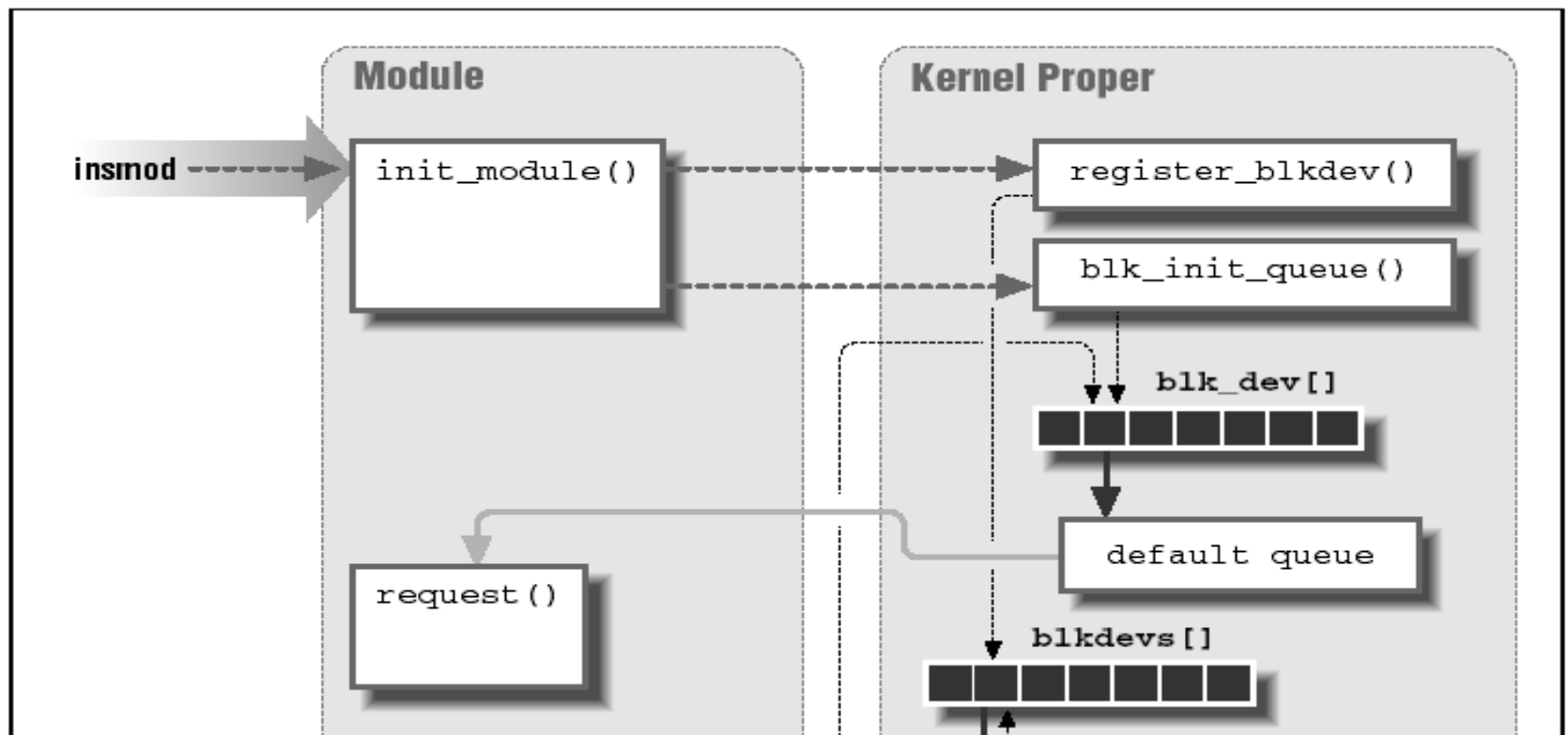

Registering a Block Device Driver(2)

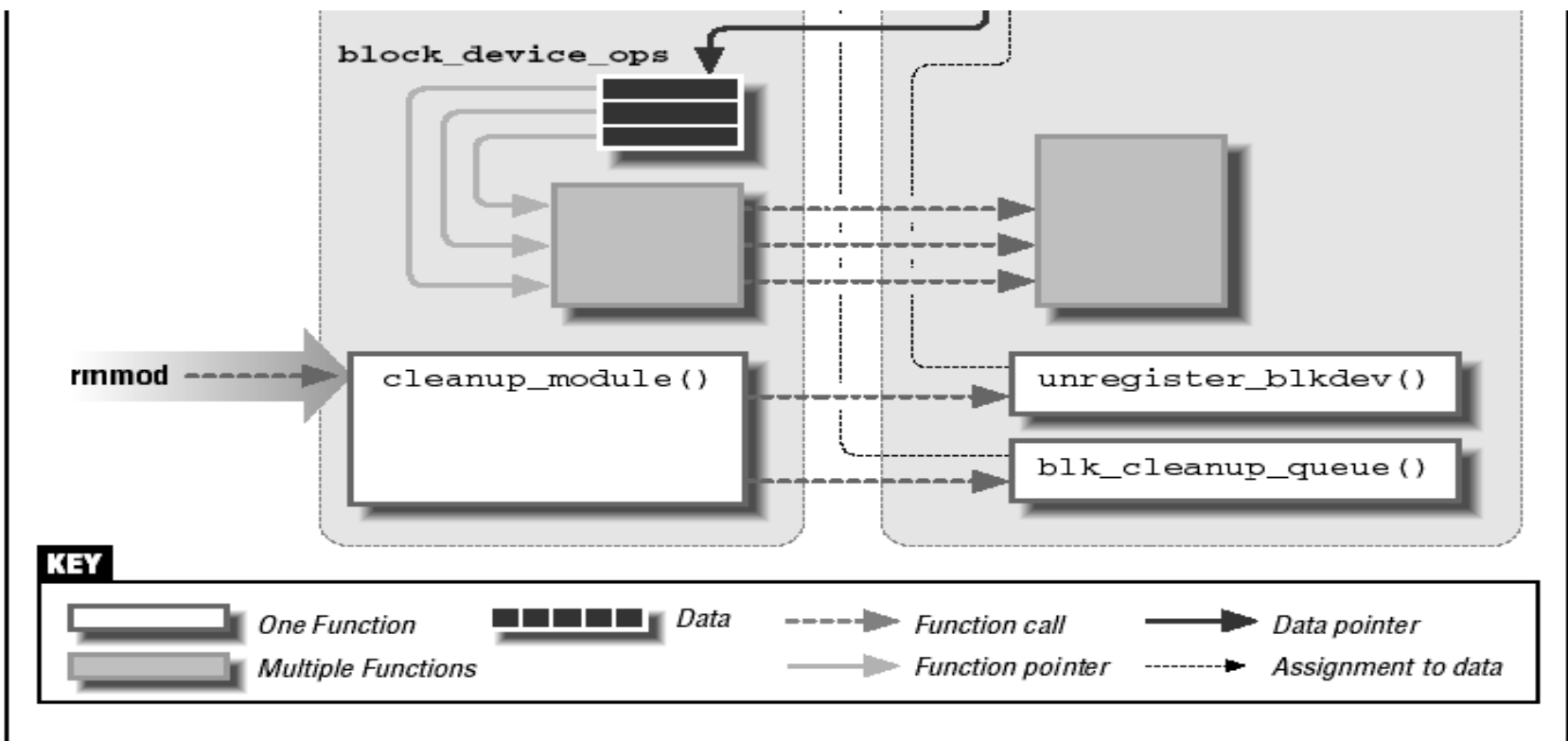

The floppy driver (1)

/drivers/block/floppy.c

```
int init_module(void)
{
    if (floppy)
        parse_floppy_cfg_stri
    return floppy_init();
}
int __init floppy_init(void)
{
    . . . . .
    devfs_handle = devfs_mk_dir (NULL, "floppy", NULL);
    if (devfs_register_blkdev(MAJOR_NR,"fd",&floppy_fops)) {
        printk("Unable to get major %d for floppy\n",MAJOR_NR);
        return -EBUSY;
    }
    . . . . .
```

/drivers/char/lp.c static struct

```
block_device_operations floppy_fops = {
    owner:    THIS_MODULE,
    open:    floppy_open,
    release:  floppy_release,
    ioctl:   fd_ioctl,
    check_media_change:
            check_floppy_change,
    revalidate:
            floppy_revalidate,};
```

The floppy driver (1a)

/drivers/block/floppy.c

```
int init_module
```

```
{
```

```
    if (floppy
```

```
        pa
```

```
    return flo
```

```
}
```

```
int __init flo
```

```
{
```

```
    . . . . .
```

```
    devfs_handle = d..._mk_dir (NULL, "floppy", NULL);
```

```
    if (devfs_register_blkdev(MAJOR_NR,"fd",&floppy_fops)) {
```

```
        printk("Unable to get major %d for floppy\n",MAJOR_NR);
```

```
        return -EBUSY;
```

```
    }
```

```
    . . . . .
```

/fs/devfs/base.c

```
int devfs_register_blkdev (unsigned int major, const  
char *name, struct block_device_operations *bdops)
```

```
{
```

```
    if (boot_options & OPTION_ONLY)
```

```
        return 0;
```

```
    return register_blkdev (major, name, bdops);
```

```
}
```

TU

/fs/devfs/base.c

```
int register_blkdev( . . . ){
    if (major == 0) {
        for (major = MAX_BLKDEV-1; major > 0; major--) {
            if (blkdevs[major].bdops == NULL) {
                blkdevs[major].name = name;
                blkdevs[major].bdops = bdops;
                return major;          }          }

            return -EBUSY;          }
        if (major >= MAX_BLKDEV)
            return -EINVAL;
        if (blkdevs[major].bdops && blkdevs[major].bdops != bdops)
            return -EBUSY;
        blkdevs[major].name = name;
        blkdevs[major].bdops = bdops;
        return 0;
    }
}
. . . . .
```

The floppy driver (2)

/drivers/block/floppy.c

```
int __init floppy_init(void)
{
    . . . . .
    blk_init_queue(BLK_DEFAULT_QUEUE(MAJOR_NR), DEVICE_REQUEST);
    . . . . .
    if (floppy_grab_irq_and_dma()){
        del_timer(&fd_timeout);
        blk_cleanup_queue(BLK_DEFAULT_QUEUE(MAJOR_NR));
        devfs_unregister_blkdev(MAJOR_NR, "fd");
        return -EBUSY;
    }
    . . . . .
}
```

The floppy driver (3)

/drivers/block/floppy.c

```
void cleanup_module(void)
{
    int dummy;

    devfs_unregister (devfs_handle);
    devfs_unregister_blkdev(MAJOR_NR, "fd");

    blk_cleanup_queue(BLK_DEFAULT_QUEUE(MAJOR_NR));
    /* eject disk, if any */
    dummy = fd_eject(0);
}
```

/drivers/block/floppy.c

```
#ifndef fd_eject
#define fd_eject(x) -EINVAL
#endif
```

Reference

- | **Understanding the LINUX KERNEL - O' reilly**
- | **Linux Device Drivers - O' reilly**
- | **Linux Kernel Internal – Addison Wesley**